

**Modular Cooking Range Line
 thermaline 90 - 23 lt Well Freestanding
 Electric Deep Fat Fryer, 1 Side,
 Backsplash, H=700**

ITEM # _____

MODEL # _____

NAME # _____

SIS # _____

AIA # _____



589301 (MCFCEBEDAO) 23lt electric Deep Fat Fryer,
 one-side operated with
 backsplash

Short Form Specification

Item No. _____

Unit constructed according to DIN 18860_2 with 20 mm drop nose top and 70 mm recessed plinth. Internal frame for heavy duty sturdiness in stainless steel. 2 mm top in 1.4301 (AISI 304). Flat surface construction, easily cleanable. THERMODUL connection system enables seamless worktop when units are connected and avoids soil penetrating. Appliance designed to deep fry meat, fish and vegetables (french fries). Deep drawn V-shaped well with external heating elements to facilitate cleaning operations. Indirect oil heating system and uniform heat distribution for extended oil life. Electronic sensor for precise oil temperature control. Reduced power setting to melt solid fat. Oil can be easily drained via a ball-valve. All-round basin raised edges to protect against soil infiltration. Large overflow stamped area around the well. Overheat protection switches off the supply in case of overheating. Standby function saves energy and quickly recovers maximum power. Metal knobs with embedded hygienic silicon "soft" grip enable easier handling and cleaning. IPX5 water resistant certification.
 Configuration: Freestanding, One-side operated with backsplash.

Main Features

- All major components may be easily accessed from the front.
- THERMODUL connection system creates a seamless work top when units are connected to each other thus avoiding soil penetrating vital components and facilitating the removal of units in case of replacement or service.
- Metal knobs with embedded hygienic "soft-touch" grip for easier handling and cleaning. The special design of the controls prevents infiltration of liquids or soil into vital components.
- Overheat protection: the temperature sensor switches off the supply in case of overheating.
- Large visible digital display manufactured in tempered glass to resist heat and chemicals, showing temperatures or power settings. The display also shows on/off status of the appliance and on/off status of the heating elements.
- Raised edge all around the well to protect from infiltration of dirt from worktop.
- Deep drawn V-Shaped well.
- Large overflow stamped area, located around the well.
- External heating elements allow to easily clean the well.
- Indirect oil heating system and uniform heat distribution to guarantee extended oil life.
- Reduced power setting to melt solid fat.
- Oil level mark for MAX/MIN filling.
- Designed for deep fat frying of meat, fish, specialities and vegetable (french fries, chips).
- Oil can be drained off via a ball-valve with a lock to prevent unintentional opening. When opened, the ball valve provides a full cross-section opening to easily clean the drainage system.
- Electronic sensor for precise oil temperature control.

Construction

- 2 mm top in 1.4301 (AISI 304).
- Unit constructed according to DIN 18860_2 with 20 mm drop nose top and 70 mm recessed plinth.
- Flat surface construction with minimal hidden areas to easily clean all surfaces
- IPX5 water resistance certification.
- Internal frame for heavy duty sturdiness in stainless steel.

Sustainability

- Standby function for energy saving and fast recovery of maximum power.
- This model is compliant with Swiss Energy Efficiency Ordinance (730.02).

APPROVAL: _____

Front

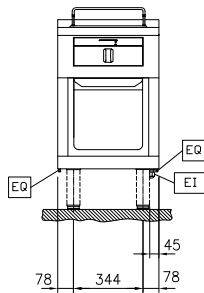

Side

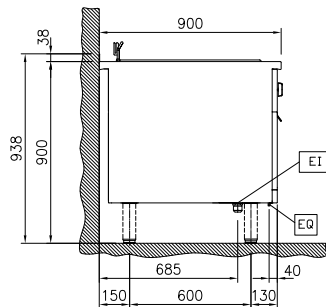

EI = Electrical inlet (power)
 EQ = Equipotential screw

Top

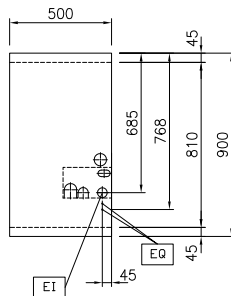
Electric

Supply voltage: 400 V/3N ph/50/60 Hz
 Total Watts: 18 kW

Key Information:

Number of wells: 1
 Usable well dimensions (width): 340 mm
 Usable well dimensions (height): 250 mm
 Usable well dimensions (depth): 400 mm
 Well capacity: 20 lt MIN; 23 lt MAX
 Thermostat Range: 100 °C MIN; 180 °C MAX
 External dimensions, Width: 500 mm
 External dimensions, Depth: 900 mm
 External dimensions, Height: 700 mm
 Net weight: 85 kg
 Configuration: On Base; One-Side Operated

Sustainability

Current consumption: 26 Amps

Included Accessories

Optional Accessories

• Discharge vessel for 14 & 23lt fryers	PNC 911570	<input type="checkbox"/>	• Side reinforced panel only in combination with side shelf, for against the wall installations, right	PNC 913269	<input type="checkbox"/>
• Lid for discharge vessel 14 & 23lt fryers	PNC 911585	<input type="checkbox"/>	• Stainless steel lower side panel (12,5mm), 900x300mm, left side, wall mounted	PNC 913643	<input type="checkbox"/>
• Connecting rail kit for appliances with backsplash, 900mm	PNC 912499	<input type="checkbox"/>	• Stainless steel lower side panel (12,5mm), 900x300mm, right side, wall mounted	PNC 913644	<input type="checkbox"/>
• Portioning shelf, 500mm width	PNC 912523	<input type="checkbox"/>	• Wall mounting kit for units - TL85/90 - Factory Fitted (H=700)	PNC 913655	<input type="checkbox"/>
• Portioning shelf, 500mm width	PNC 912553	<input type="checkbox"/>	• Filter W=500mm	PNC 913664	<input type="checkbox"/>
• Folding shelf, 300x900mm	PNC 912581	<input type="checkbox"/>	• Stainless steel dividing panel, 900x700mm, (it should only be used between Electrolux Professional thermaline Modular 90 and thermaline C90)	PNC 913672	<input type="checkbox"/>
• Folding shelf, 400x900mm	PNC 912582	<input type="checkbox"/>	• Stainless steel side panel, 900x700mm, flush-fitting (it should only be used against the wall, against a niche and in between Electrolux Professional thermaline and ProThermetic appliances and external appliances - provided that these have at least the same dimensions)	PNC 913688	<input type="checkbox"/>
• Fixed side shelf, 200x900mm	PNC 912589	<input type="checkbox"/>			
• Fixed side shelf, 300x900mm	PNC 912590	<input type="checkbox"/>			
• Fixed side shelf, 400x900mm	PNC 912591	<input type="checkbox"/>			
• Stainless steel front kicking strip, 500mm width	PNC 912631	<input type="checkbox"/>			
• Stainless steel side kicking strips left and right, against the wall, 900mm width	PNC 912660	<input type="checkbox"/>			
• Stainless steel side kicking strip left and right, back-to-back, 1810mm width	PNC 912663	<input type="checkbox"/>			
• Stainless steel plinth, against wall, 500mm width	PNC 912936	<input type="checkbox"/>			
• Connecting rail kit for appliances with backsplash: modular 90 (on the left) to ProThermetic tilting (on the right), ProThermetic stationary (on the left) to ProThermetic tilting (on the right)	PNC 912981	<input type="checkbox"/>			
• Connecting rail kit for appliances with backsplash: modular 90 (on the right) to ProThermetic tilting (on the left), ProThermetic stationary (on the right) to ProThermetic tilting (on the left)	PNC 912982	<input type="checkbox"/>			
• Back panel, 500x700mm, for units with backsplash	PNC 913010	<input type="checkbox"/>			
• Stainless steel panel, 900x700mm, against wall, left side	PNC 913101	<input type="checkbox"/>			
• Stainless steel panel, 900x700mm, against wall, right side	PNC 913105	<input type="checkbox"/>			
• Endrail kit, flush-fitting, with backsplash, left	PNC 913117	<input type="checkbox"/>			
• Endrail kit, flush-fitting, with backsplash, right	PNC 913118	<input type="checkbox"/>			
• Sediment tray for 23lt deep fat fryer	PNC 913144	<input type="checkbox"/>			
• Filter for deep fat fryer oil collection basin	PNC 913146	<input type="checkbox"/>			
• Endrail kit (12.5mm) for thermaline 90 units with backsplash, left	PNC 913208	<input type="checkbox"/>			
• Endrail kit (12.5mm) for thermaline 90 units with backsplash, right	PNC 913209	<input type="checkbox"/>			
• U-clamping rail for back-to-back installations with backsplash (to be ordered as S-code)	PNC 913226	<input type="checkbox"/>			
• Insert profile d=900	PNC 913232	<input type="checkbox"/>			
• Energy optimizer kit 32A - factory fitted	PNC 913247	<input type="checkbox"/>			
• Side reinforced panel only in combination with side shelf, for against the wall installations, left	PNC 913267	<input type="checkbox"/>			